

The Path of Information Philosophy to Solve the Defect of Einstein's Integration of Space–Time

Amelia Clarke

Abstract

This paper presents a novel lab and project-based learning introductory robotics course recently created and offered at Stevens Institute of Technology, Hoboken, NJ USA. The course is offered through the Mechanical Engineering Department for upper-class undergraduate students and first year graduate students. This paper details the innovative hands-on robotics platforms, labs, and final project competition events created for this class. It also discusses the results from a student survey from its initial offering and the ensuing course improvements that have resulted from it.

Introduction

Much attention has been spent in recent years on college-level robotics education [1-7]. There have also been workshops at prominent robotics conferences [8, 9] and special journal issues on trends in robotics education [10]. In Ref. [11], the authors argue that the most efficient way of teaching true knowledge and understanding for robotic systems is to let the students work on real systems instead of academic problems and to let them build and experience them. A strategy to maximize the learning experience and promote intellectual development of the students and to teach system integration schemes at the university level is robotic design competitions [12, 13]. A competition can bolster the intellectual maturity of students who begin to accept that there may be more than one right answer to a problem. It also encourages the students to identify many problems, evaluate the solutions, work in a group, and directly apply knowledge. Competition has also been discussed as a method of advancing robotics, motivating students, and making the learning experience more extensive [12, 14-16]. These

approaches to robotics education through hands-on experience and robotic design competitions were utilized when designing this new introductory robotics course for upper level undergraduate students and first year graduate students. The course is entitled *Introduction to Robotics* and is offered through the Mechanical Engineering Department at Stevens Institute of Technology, Hoboken, NJ USA. It was offered for the first time in the Spring 2009 semester. A lab and project-based learning [17,18] curriculum was developed along with traditional classroom lectures. This paper presents an overview of the course syllabus and format followed by detailed descriptions of the novel robot platforms, labs and projects developed as part of the course. Outcomes from the initial offering are presented along with the resulting course improvements.

Class Format and Syllabus

Most traditional introductory robotics courses in the past have focused primarily on robotic manipulators. It is only very recently that text books on mobile robots and courses have started to emerge into the collegiate curriculum. The format for this introductory robotics course covers both of these topics during a 15-week semester offering. The course is divided in to two 7-week segments, with a final project competition event held in the last week. The first half of the course is devoted to robotic manipulators while the second half is on autonomous mobile robots. Consequently, there are two required text books for the course. The first one is *Robot Modeling and Control* by Spong et al. [19] for use with the robotic manipulator part of the course. The second text book is *Introduction to Autonomous Mobile Robots* by Siegwart and Nourbakhsh [20].

The sample syllabus for the course is shown in Figure 1. There are a series of lectures and labs throughout the course, with the lectures front loaded to allow for extra lab sessions towards the end of the course for students to focus on a final term project competition event.

Robotic Manipulators		Autonomous Mobile Robots	
Week	Material	Week	Material
1	Course Overview, Robotics Introduction Rotations and Transformations	8	Final Project Intro; Mobile Robot Intro/Kinematics
2	Forward Kinematics, DH Parameters Inverse Kinematics	9	Midterm Project Demos; Mobile Robot Lab 1
3	Velocity Kinematics; Teleoperation Midterm Project Intro; Manipulator Lab 1	10	Computer Vision/Image Processing; Sensor-Based Navigation; Mobile Robot Lab 2
4	Manipulator Path and Trajectory Planning;	11	Localization, Path Planning and Navigation; Mobile Robot Lab 3
5	Independent Joint Control; Manipulator Lab 2	12	Final Project Lab Session
6	Actuators and Sensors; Review for Midterm	13	Final Project Lab Session
7	MIDTERM	14	Final Project Competition
		15	Final Report Due

Figure 1: Course Format and Syllabus.

In the first half of the class, the lectures cover the following topics: Forward and Inverse Kinematics, Denavit-Hartenberg Parameters, The Jacobian, Trajectory Planning, Independent Joint Control, Actuators and Sensors. Traditional problem sets are assigned weekly in addition to two hands-on labs along with a take-home midterm for assessment. In the second half of the class, lectures cover: Mobile Robot Kinematics, Computer Vision, Localization, and Motion Planning. In this part of the class, the only assignments and assessment is through labs and the final project. The labs and projects are the hallmark of this course, linking the classroom lectures to hands-on experience and keeping the students motivated and focused throughout the semester. Thus, this top-down approach [21] utilizes the labs and project to motivate and teach the students fundamental concepts. There are two labs dealing with robotic manipulators (Manipulation Lab 1 and 2) and three labs on autonomous mobile robots (Mobile Robots Lab 1-3). The course is structured so that the skills taught and learned in the classroom and labs build towards the final project. The final project competition event is

designed to incorporate the tools learned from the individual labs in order to successfully complete it. New in the second year of the course offering is a midterm project, designed to link together the manipulator and mobile robot parts of the course and final project together.

Manipulator Labs

Robot Platform

The platform for the manipulator labs is the Intelitek SCOREBOT-ER 4pc robot [22] (Figure 2(a)). The robot is a vertical articulated robot with five revolute joints. There is a gripper end-effector, yielding six degrees-of-freedom for the robot.

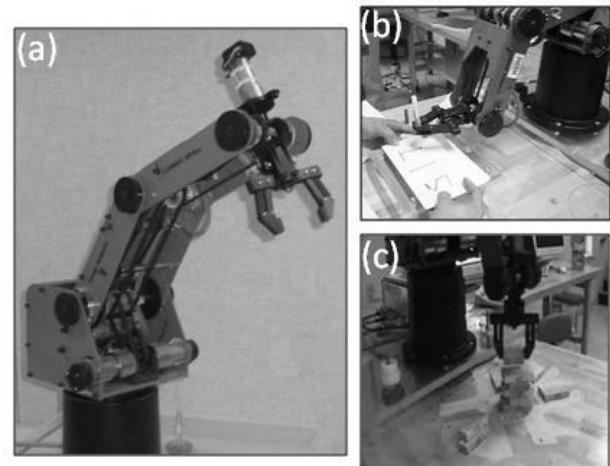

Figure 2: Manipulation Labs: (a) Intelitek SCOREBOT Manipulator; (b) Lab 1: Kinematics and Path Planning; (c) Lab 2: Palletizing Task

Manipulator Lab 1

Manipulator Lab 1 is used to familiarize the students with the kinematics, path planning, and the programming interface for the SCOREBOT robot. There are five parts to this lab. In Part 1, the students are tasked with identifying the configuration of the robot and determining its workspace. A table of joint limits is given, while the actual link lengths need to be measured and the workspace sketched. For Part 2, the forward kinematic transform for this

robot, using the Denavit-Hartenberg parameters, needs to be derived. Part 3 follows with the derivation of the inverse position kinematics for the manipulator. In Part 4, these calculations need to be verified from data taken from the actual robot in three different configurations. Finally, in Part 5 the students need to program the robot to write out the initials for the school (SIT) on a piece of paper with a marker (Figure 2(b)). After the robot has finished writing the initials, it has to place the marker into the corresponding hole on the platform with the back end in first (i.e. tip sticking up).

Manipulator Lab 2

Manipulator Lab 2 builds on the kinematic knowledge and introductory robot programming from Manipulator Lab 1 to program the robot for more complicated tasks, specifically to have the robot accomplish a palletizing operation. There are four part "bins" located in front of the SCOREBOT. Each bin contains 6 parts that need to be stacked into a pallet. The 6 parts are arranged in 3 rows of two parts. The top rows of parts in all the bins are orientated at 90° while the bottom rows of parts are all orientated at 0° . There are three individual parts located each between Bin 1 and Bin 2, Bin 2 and Bin 3, and Bin 1 and Bin 4, respectively. Students need to program the robot to create a pallet (stack) of all of these parts in the marked off region in the center of the robot's workspace in a specified order and orientation. They are asked to also do this manually with the robot and calculate throughput estimates for comparison purposes. An example of the robot executing the palletizing task is shown in Figure 2(c).

Mobile Robot Labs

Robot Platform

A modified iRobot Create [23] robot platform is utilized for the mobile robot labs (Figure 3). The Create robot is a differential drive mobile robot with an open interface. The Open Interface (OI) consists of an electronic interface and a software interface for controlling the

Create's behavior and reading its sensors. The software interface lets you manipulate the Create's behavior and read its sensors through a series of actuator and sensor commands that you send to Create's serial port by way of a control computer or microcontroller. The Bluetooth Accessory Module (BAM) [24] is used to connect a control computer wirelessly to the robot. The Matlab Toolbox for the iRobot Create (MTIC) [25] is used to communicate with the robot from a host control computer through Matlab [26]. The toolbox replaces the native low-level numerical commands of the OI software, with a set of high level, intuitive, Matlab functions. It links the host computer and the Create using the computer's Bluetooth connection, provides drive commands, reads on-board sensors, determines distance driven, and battery life. It allows for Matlab command line or script files to control the robot, while the code is developed, stored and executed on the host computer, not the Create. A wireless internet camera [27] is mounted to the top of the Create that is able to provide real-time images for the robot control programs. The camera creates an ad-hoc network with a static IP address that the wireless card in the control computer can connect to. Each image frame can then be imported into Matlab using the Image Processing Toolbox commands.

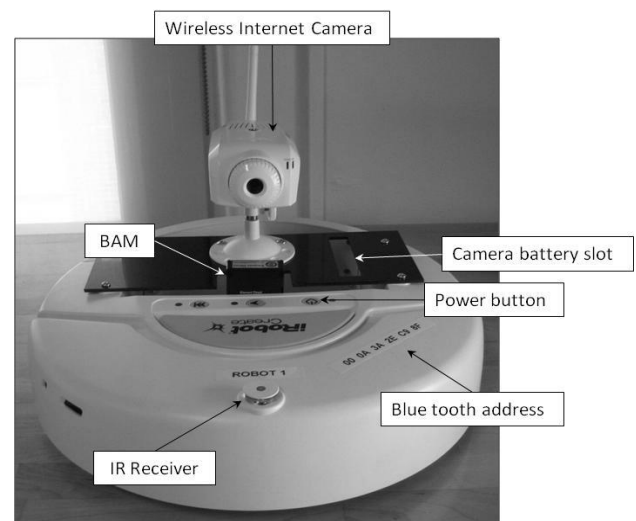

Figure 3: Modified iRobot Create Mobile Robot Platform.

Mobile Robot Lab 1

Mobile Robot Lab 1 introduces the students to the mobile robot hardware platform and teaches them how to locomote the robot through the use of its on-board sensors. Once communications to the robot have been established, the students are tasked with programming the robot to move in a square path by simply relying on the internal odometry readings of the robot. The systematic errors for the robot are then recorded to illustrate the inherent errors of the particular robot. Next, the students need to generate sensor values from the robot for all of its on-board sensors that are accessible from the MTIC. They also need to create new Matlab functions for the toolbox to read in the infrared (IR) sensor data. This sensor can sense the presence of the iRobot *Virtual Wall* or *Home Base* IR signals. In the final part of the lab, the robot needs to be autonomously programmed for sensor-based navigation. As shown in Figure 4, the robot must start from the initial position, drive to Position 1, make a 90°CW turn, drive to Position 2 and stop. From Position 2, the robot must rotate in-place, searching for the IR signal from the virtual wall. Once the IR signal is sensed, the robot should stop rotating and beep. The robot then needs to change orientation again and drive to Position 3. Once at Position 3, the cliff sensors (light intensity sensors on the bottom of the robot) need to be utilized to follow the dark lines (of arbitrary distances) and stop when the robot gets as close to the Home Base as possible without colliding with it.

Mobile Robot Lab 2

The students learn vision-based navigation in Mobile Robot Lab 2 (Figure 5). Sample color detection Matlab code is supplied so that the students can determine the centroid locations and areas of blobs in an image of the color of

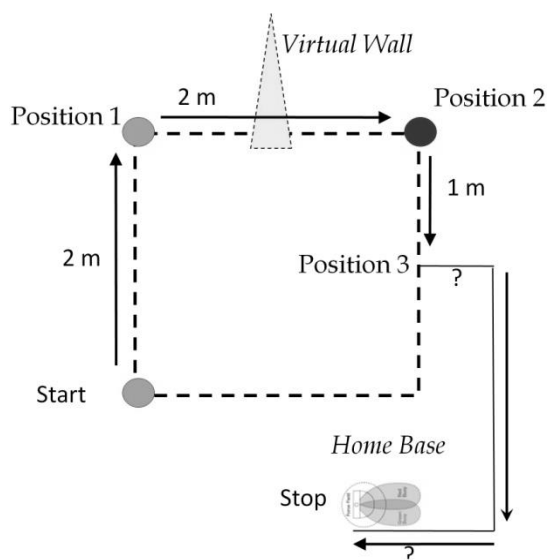

Figure 4: Mobile Robot Lab #1: Locomotion and Sensors

interest. Training images of the color to be tracked are grabbed and used to come up with average hue, saturation, and value color model parameters to identify in the color detection program. The students use the area metric to create and calibrate a vision-based distance sensor for the robot. Once calibrated, the robot is programmed to stop at a fixed distance (8") from an obstacle (orange cone). Next, a tracking task is assigned utilizing the centroid position of the blobs. Based on these coordinates, the robot is programmed to rotate so that the blob image is in the center of the field of view of the robot's camera. The final task for this lab utilizes both of these new skills to navigate the robot through slalom of three cones. Now, instead of rotating towards the cones as in the case of the tracking task, the robot needs to be programmed to rotate away from the cone in order to avoid the obstacle. Considerations for when more than one or no cones are present in the camera's field of view need to be taken into account when programming this task.

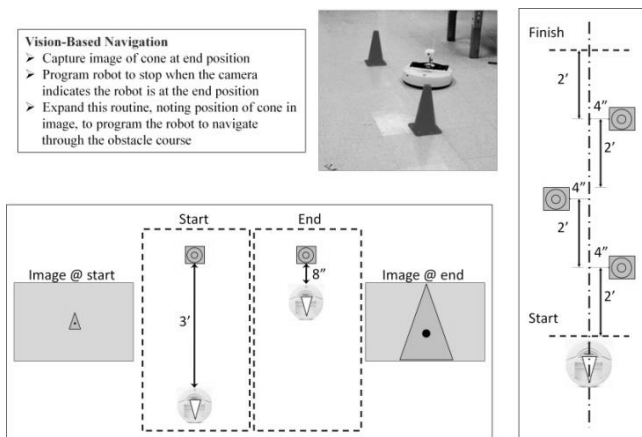

Figure 5: Mobile Robot Lab 2: Vision-Based Navigation.

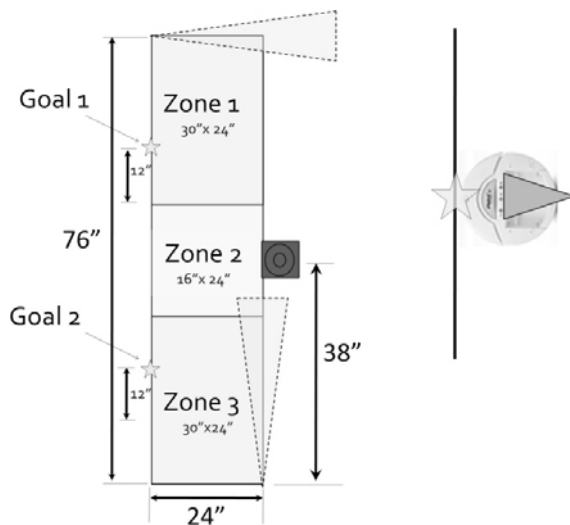

Figure 6: Mobile Robot Lab 3: Localization.

Mobile Robot Lab 3

A localization task is assigned in Mobile Robot Lab 3. The map shown in Figure 6 is provided a priori. The robot is placed in a random position and orientation in any of the three starting zones. Utilizing the robot sensors (IR sensor, camera, cliff sensors, position, angle sensors, etc.) and map the robot needs to figure out what zone it is in and then navigate to one of the two goal positions and orientate itself appropriately, as shown in Figure 6 (right). Also, in this lab the students solve a path planning problem by implementing the A* algorithm [28] on a grid and execute it with the

robot. Finally, they are required to discuss their strategy for the final project competition and provide a programming flow chart along with pseudo-code for the overall program architecture.

Final Project Competition

Description

The final project competition event was inspired by the DARPA Urban Challenge Event [29] and was termed the *Mini-Urban Challenge Event*. The project definition and competition rules are presented at the beginning of the mobile robot portion of the course and the project combines all the skills learned in the second half of the class. The objective of the project is to program the robot to autonomously navigate through an “urban environment”, obeying all traffic laws, to a goal location. The goal location is an infrared beacon (*Home Base*) in a specified location. The robot must stop as close as possible to goal location without disturbing the beacon. There are four traffic laws that must be obeyed:

- Remain on the road at all times
- Avoid all obstacles (orange cones) in the road
- Make a 3 second stop for pedestrians (blue acrylic cut-outs) encountered in intersections
- Avoid pedestrians in intersections

Rules and Scoring:

Robots will begin navigating the course (Figure 7) after being placed in either zone 1, 2, or 3 of the starting lane in a random position and orientation. Failure to properly localize (i.e. identifying incorrect starting zone, driving off course) on two consecutive attempts will result in a localization penalty and subsequent placement of the robot in the center of zone 2, facing the localization marker. The robot may now start to navigate the course from this known location and orientation with the appropriate penalty assessed.

Scoring metrics:

- Finishing time: time in seconds
- Obstacle collision penalties:
 - $(30) \times (\# \text{ of collisions})$
- Off-road penalties:
 - $(30) \times (\# \text{ of seconds off-road})$
- Pedestrian penalties:
 - $(60) \times (\# \text{ of failed stops})$
 - $(50) \times (\# \text{ of pedestrian collisions})$
- Goal collision penalties: 100/collision
- Localization penalty: 100 for failure to localize
- Distance from goal bonus if closer than 6'': $(6'' - \text{distance from goal (in inches)}) \times 15$

Final score:

Finishing time + obstacle collision penalties + off-road penalties + pedestrian penalties + goal collision penalties + localization penalties – distance from goal bonus

The lowest point total wins; each team gets at least two runs on the course, lowest score of the two runs counts.

Results

Each student team (three students/team) were able to successful navigate the course at least one time. The scoring results from the competition are shown in Table 1. The winning run was accomplished with a finishing time of 3 minutes 26 sec, no penalties assessed, and a distance from goal bonus (only 2'' from goal), resulting in a score of 146 points. Conversely, the worst run took over 4 minutes to complete and was stopped when the robot got stuck 84'' (7') from the goal location. Localization, obstacle and pedestrian collisions, failed stop, and off-road penalties resulted in a score of over 600 points. Most of the errors occurred due to the vision system not properly identifying the obstacle to avoid or drive to as a navigation landmark. Once the robot was lost it could not recover its true position. Reflections and different illumination settings during testing and the actual competition were some of the causes

for this confusion in the robot. Also, the low frame rate of the images (~1 Hz) hampered the ability of the robots to navigate the course in the most efficient manner.

Table 1: Mini-Urban Challenge Event Results.

Team Number	Run 1 (pts)	Run 2(pts)	Distance from goal (in)
1	487	DNF	84
2	DNF	146	2
3	604	498	84
4	367	220	11.5, 9.5
5	423	DNF	15
6	282	DNF	9.5
7	173	DNF	2.5

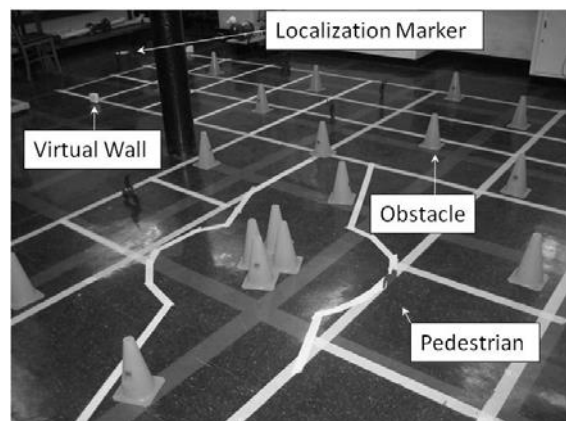
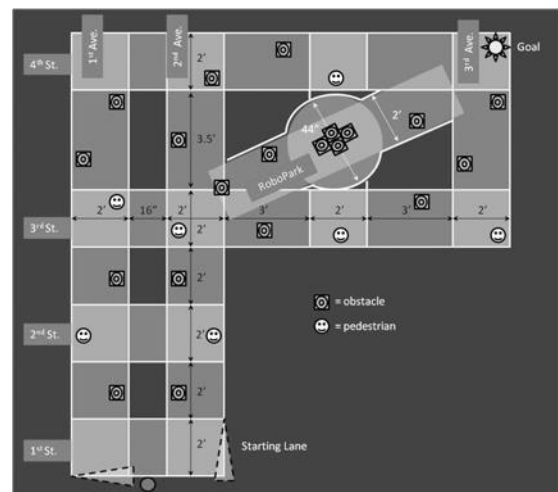

Figure 7: Final Project Mini Urban Challenge Event: Schematic (top); Implementation (bottom).

Class Feedback and Modifications

Surveys were given to the students at the mid-point and end of the semester to evaluate their experience with this new lab and project-based robotics course. All of the respondents (100%) indicated that they prefer a hands-on project based course over a traditional lecture style course. Also, 92% rated the labs as Fun or Useful – reinforcing the material that was learned in the classroom. For the second half survey, 85% of the respondents preferred lab assignments over problem sets for assessment, while only a small percentage preferred the more structured problem sets like those given in the first half of the course. About 30% commented that they would like to do some mechanical work on the robot as opposed to just programming it, as all those enrolled were mechanical engineering majors. The students also said they wished they had more time between Mobile Robot Lab 3 and the Final Project Competition day to devote to the final project. As the instructor, I felt that there was a little disconnect from the first half of the class on manipulators to the second half on autonomous mobile robots.

Therefore, based on this feedback the course was modified accordingly for its next offering in the Spring 2010 semester. The syllabus was restructured to allow for two weeks of open-lab project sessions after the last mobile robot lab and before the final competition day. Previously, there was only one week for this. Also, to bridge the gap between the manipulators and mobile robot sections and to add more of a mechanical aspect of the course, a midterm project was introduced. The labs have stayed the same but a new final project competition has been created to incorporate the new midterm project and both halves of the course. The midterm project deals with designing and building a robotic manipulator for the Create robot, while the new final project is a mobile manipulation challenge event. Both will be described now.

Midterm Project

The objective of the midterm project is to design, fabricate, and program a robotic arm for autonomous use on top of the Create mobile robot platform. The goal task is to pick up a payload from a known location and release the payload into the storage bin while avoiding obstacles (the wall) and restricted areas in the workspace of the robot manipulator, as shown in Figure 8. The robot manipulator to be designed consists of three rigid links with revolute joints, each actuated with servo motors, and an end-effector. The end-effector is a rigid link with an electromagnet that is programmed to pick up or release the payload of interest. It has a revolute joint with the last link of the robot that is passive, allowing the electromagnet to always dangle in the vertical direction below the end of this link. The robot must be designed, fabricated, and programmed to pick up a magnetic payload with the end-effector and place it in the storage bin. The restricted area above the mounting plate that the robot links may not interfere with is where the camera system for the Create robot resides. The initial configuration for the robot must be entirely behind the wall and entirely below the top of the wall (18").

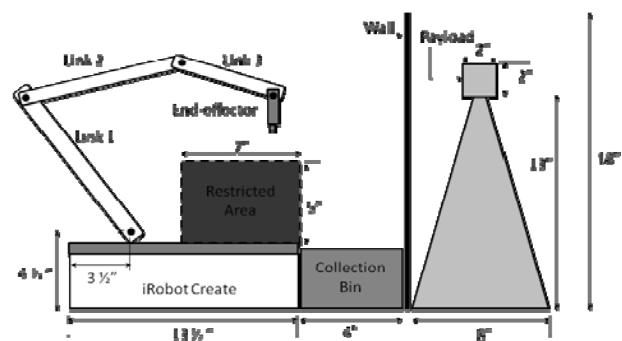

Figure 8: Midterm Project Schematic.

For the mechanical design of the robot arm, the students must choose appropriate link lengths to satisfy the workspace and task requirements and justify their choices through (forward or inverse) kinematic validation. Once

the link lengths have been designed, they are laser cut out of 1/8" thick acrylic by the teaching assistants to size and distributed to each team with rest of the required hardware components to assemble the robot along with assembly and wiring instructions. A fully assembled arm is shown in Figure 9 (top) while a schematic of the wiring diagram for the key electronic components are shown at the bottom of the figure. A Parallax Basic Stamp II (BS2) microcontroller is used to send commands to a Parallax Propeller Servo Controller to control the joint angles of the robot links [30]. The BS2 is also used to turn the electromagnet [31] on/off. Once debugged, the sequence of operations to accomplish the task are downloaded into the BS2 and initiated with an input signal from the BAM module that resides on the Create robot. When the BS2 receives this signal, it will initiate the program. The signal from the BAM is sent wirelessly from Matlab utilizing the MTIC and the Create OI.

***Final Project Competition:
Mobile Manipulation Challenge***

This final project competition event is similar to the previous final project competition where the robots must autonomously localize and navigate a course to get to a goal location while avoiding obstacles. However, the robots have the additional task of picking up and placing payloads in collection bins along the way. Dark lines have been added in strategic locations to help with navigation tasks. An overall strategy needs to be determined based on the skill of the robot and the zone scoring rules (Table 2). A schematic of the new final project course is shown in Figure 10.

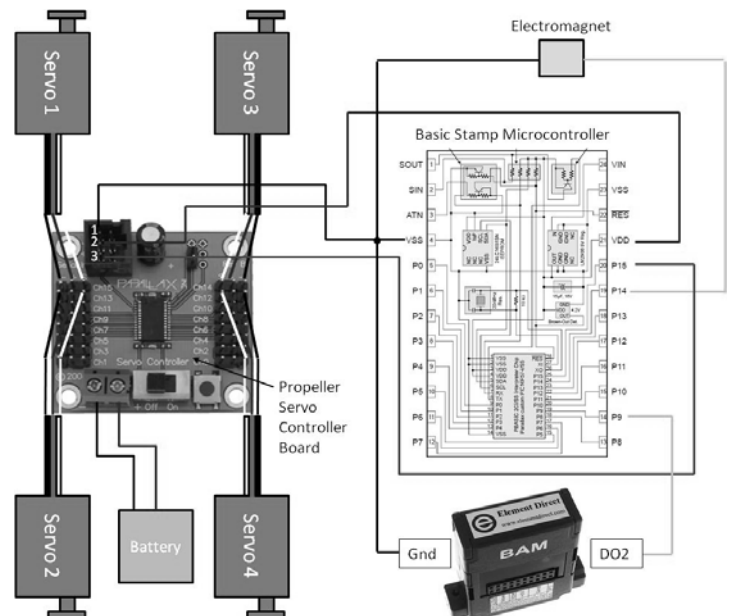
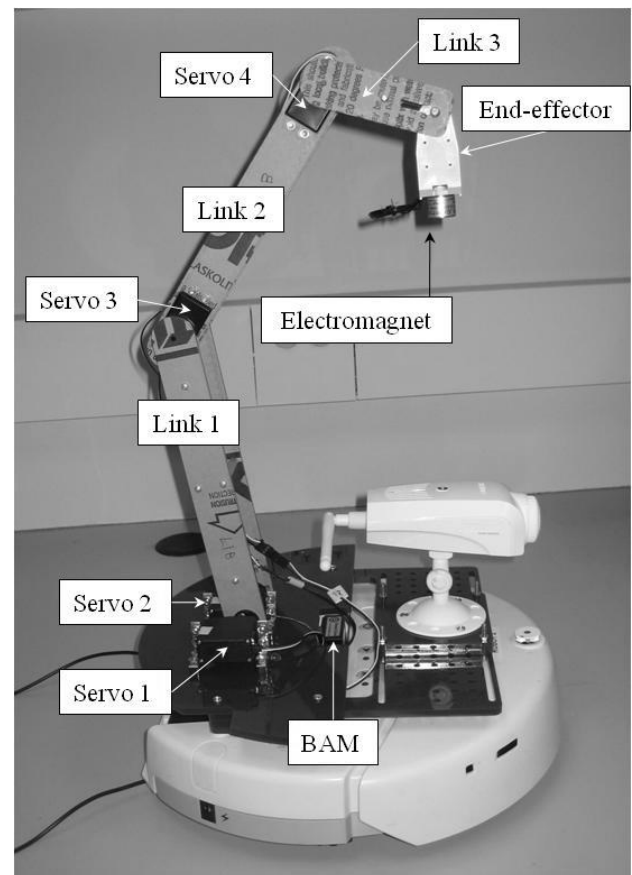

Figure 9: Midterm Project: Designed Manipulator on Mobile Robot Platform (top); Wiring schematic (bottom).

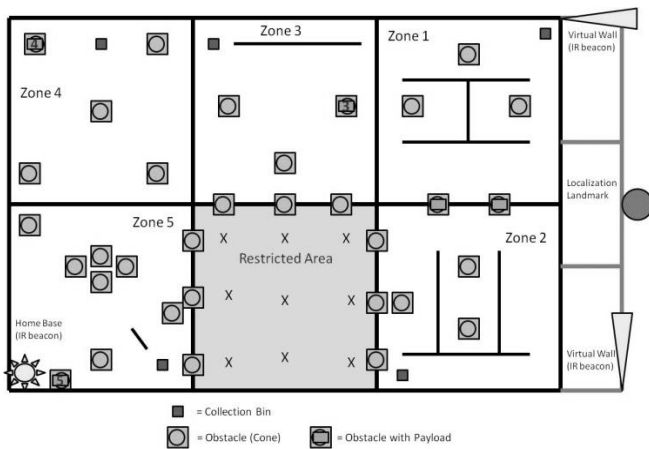

Figure 10: Final Project Schematic: Mobile Manipulation Challenge Event.

The ultimate goal is to drop off payload 5, located in Zone 5, in the collection bin, also located in Zone 5 while accumulating the most points as possible along the way. There is a 10 minute time limit for navigating the course. The clock stops after a failed pick-up attempt or drop attempt in Zone 5. If there is a successful payload drop in Zone 5, the team qualifies for a time bonus: $\text{Time Bonus} = (\# \text{ of seconds under } 10 \text{ min}) \times (\# \text{ of successful drops in Zones } 1\text{-}4)^2$. Penalties are the following: -100 pts/obstacle collision; -100 pts/sec in restricted area. The points obtained for scoring actions change depending on the zone in the course, as listed in Table 2. The team with the highest cumulative score wins.

Table 2: Mobile Manipulation Challenge: Zone Scoring

Scoring Action	Zone 1	Zone 2	Zone 3	Zone 4	Zone 5
Pick-up attempt	10 pts	10 pts	10 pts	25 pts	50 pts
Successful pick-up	15 pts	15 pts	15 pts	25 pts	25 pts
Successful Drop	25 pts	75 pts	50 pts	100 pts	125 pts

Conclusions

In conclusion, a new novel lab and project-based learning introductory robotics course has been presented. Initial results from the first offering of the course have been overwhelmingly positive. The students really enjoyed and preferred the hands-on labs and open ended final project over a traditional lecture only course. Anecdotal positive feedback has been obtained on the course improvements to coherently tie the robotic manipulator and autonomous mobile robot portions of the class together with the new midterm project and final project. A detailed survey at the end of the second instantiation is planned to quantify these results and solicit suggestions for future improvements. Teaching a hands-on lab and project-based course such as this requires lots of overhead and extra work from the instructor, TA’s, and the students. However, the abilities that the students gain in respect to identifying many different problems, evaluating the solutions, working in a group, and directly apply the knowledge presented in the class-room in the real-world are well worth the effort.

References

1. D. Kumar and L. Meeden, "A robot laboratory for teaching artificial intelligence", *Proceedings of SIGCSE*, 1998.
2. R. Manseur, "Development of an undergraduate robotics course", *Proceedings of IEEE FIE*, pp. 610–612, 1997.
3. S. Shamilian, K. Killfoile, R. Kellogg, and F. Duvallet, "Fun with robots: A student-taught undergraduate robotics course". *Proceedings of the 2006 IEEE International Conference on Robotics and Automation*, Orlando, FL, May 2006, pp. 369–374.
4. M. Guo, L. Husman, N. Vullum, and A. Friesel, "Project in robotics at the Copenhagen University College of Engineering". *Proceedings of the 2004 IEEE International Conference on Robotics and Automation*, May 2004.
5. J. Garner, W. Smart, and K. Bennett. "The remote exploration program: A collaborative outreach approach to robotics education". *Proceedings of the 2004 IEEE International Conference on Robotics and Automation*, May 2004.
6. K. Rawat, and G. Massiha, 2004. "A hands-on laboratory based approach to undergraduate robotics education". *Proceedings of the 2004 IEEE International Conference on Robotics and Automation*, May 2004.
7. J. Peipmeier, B. Bishop, and K. Knowles, "Modern robotics engineering instruction". *Robotics & Automation Magazine*, 10(2), June 2003, pp. 33–37.
8. ICRA, "Workshop on educational robotics". *International Conference on Robotics and Automation*, May 2004.
9. RSS. "Robotics education workshop". *Robotics Science and Systems*, June 2005.
10. IJEE, "Special issue: Trends in robotics education". *International Journal of Engineering Education*, 22(4), April 2006.
11. R. Siegwart, "Grasping the interdisciplinarity of mechatronics". *Robotics & Automation Magazine*, 8(2), June 2001, pp. 27–34.
12. R. Murphy, "Competing for a robotics education". *IEEE Robotics and Automation Magazine*, vol. 8, no. 2, June 2001.
13. A. Baerveldt, T. Salomonsson, B. Astrand, "Vision-guided mobile robots for design competitions". *Robotics & Automation Magazine*, 10(2), June 2003, pp. 38–44.
14. M. Yim, K. Kuchenbecker, J. Bassani, P. Arratia, V. Kumar, J. Fiene, and J. Lukes. "A Practice-Integrated undergraduate curriculum in mechanical engineering," in *Proc. ASEE Conf. and Expo*, Pittsburgh, PA, June 2008.
15. P. Fiorini, and D. Kragic. "Education by competition," *IEEE Robotics and Automation Magazine*, vol. 13, no. 3, Sept. 2006.
16. M. Chew, S. Demidenko, C. Messom, and G. Gupta. "Robotics competitions in engineering education," in *Proc. of Int'l Conf. Autonomous Robots and Agents*, Wellington, NZ, Feb. 2009.
17. G. Heitmann, "Project-oriented study and project-organized curricula: A brief review of intentions and solutions," *European Journal of Engineering Education*, vol. 21, no. 2, June 1996.

18. J.E. Mills, and D.F. Treagust, "Engineering education: Is problem-based or project-based learning the answer?" *Australasian Journal and Engineering Education*, 2003.
19. M. Spong, S. Hutchinson, and M. Vidyasagar, *Robot Modeling and Control*, 1st ed., John Wiley & Sons, Inc., Hoboken, 2006.
20. R. Siegwart, I. Nourbakhsh, *Introduction to Autonomous Mobile Robots*, 1st ed., MIT Press, Cambridge, 2004.
21. D. Cappelleri, J. Keller, T. Kientz, P. Szczesniak, and V. Kumar, "SAAST Robotics: An intensive three week robotics program for high school students," In *Proc. ASME Int'l Design Engineering Technical Conference*, Las Vegas, NV, Sept. 2007.
22. Intelitek, www.intelitek.com
23. iRobot Corp., www.irobot.com
24. Element Direct, www.elementdirect.com
25. J. Esposito, O. Barton, "Matlab Toolbox for the iRobot Create" www.usna.edu/Users/weapsys/esposito/roomba.matlab/ , 2008.
26. The MathWorks, Inc., www.mathworks.com
27. TRENDNet, www.trendnet.com
28. H. Choset, K. M. Lynch, S. Hutchinson, G. Kantor, W. Burgard, L. E. Kavraki and S. Thrun *Principles of Robot Motion: Theory, Algorithms, and Implementations*, MIT Press, Boston, 2005.
29. DARPA Urban Challenge, www.darpa.mil/grandchallenge/index.asp
30. Parallax, Inc., <http://www.parallax.com>.
31. APW Company, www.apwcompany.com